

ARC ROOF 8X6



SYSTEM DESCRIPTION

The Arc Roof is a fixed construction, based on three inward-curving trusses that are mounted to side masts. Special corners connect the arches to the main grid. Different configurations are made possible by simply changing the arches. The arched trusses have a keder profile on top for fitting the optional canopy.

INCLUDING

- Tension gear and steel wires
- Comprehensive building manual
- Structural report

Structure

Main grid	H30D
Towers	H30V
Roof structure	Arc Roof
Stiffening	Guywires + Pressure bars

Loading capacity

Description	Type	Totals
Maingrid*	UDL	1950kg
	CPL	950kg
	Point load combination	2100kg
PA wing	CPL per wing	1000kg

*Exact figures depend on configuration and loading plan

Why?

- Easy to handle, quick setup
- Significant loading capacity
- Versatile application

Logistic

Self-weight structure	800kg
Transport volume structure	20m ³
Exact figures depends on configuration and loading plan	

Assembling

Build up approximately	6 hours (4 persons)
Dismantling approximately	4 hours (4 persons)
All these numbers varies depending on weather conditions, amount of persons available and skills of the crew.	

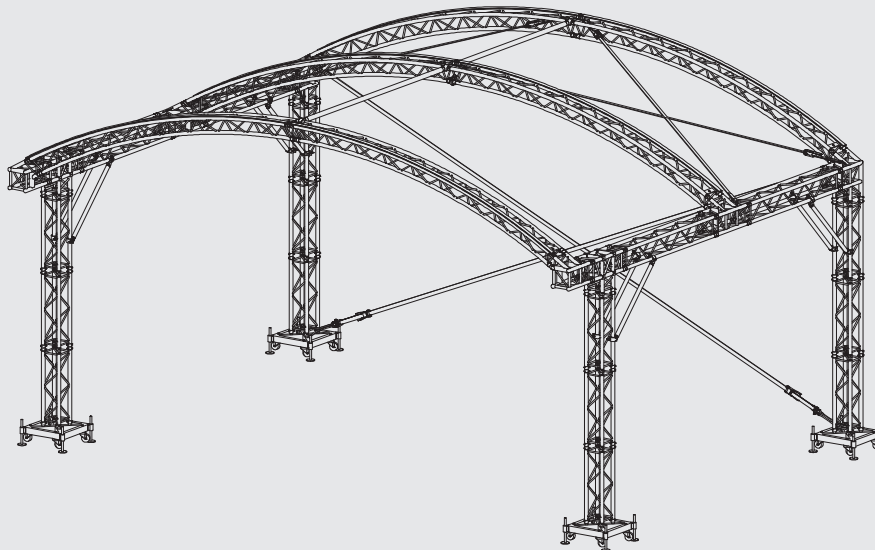

ARC ROOF 8X6

Design standards

ISO-17842-1 (2015)	Safety of amusement rides and amusement devices -- Part 1: Design and manufacture
EN 13814-1 (2015)	Fairground and amusement park machinery and structures - Safety
EUROCODE 0 (EN-1990)	Basis of structural design
EUROCODE 1 (EN-1991)	Actions on structures
EUROCODE 3 (EN-1993)	Design of steel structures
EUROCODE 9 (EN-1999)	Design of aluminum structures

- All structural components/structures are produced according EN1090 EXC3.
- All structures are supplied with a structural report and manual – an on-site training is mandatory

Wind management

According ISO-17842-1 (2015)

(wind loading valid for area Vb,0 = 28m/s – terrain category III)

Out-Service	0,44kN/m ²	26,5 m/s – 95,4km/hr (Max. gust wind speed)
In-Service	0,20kN/m ²	17,9 m/s – 64,4km/hr (Max. gust wind speed)
Measures	Upon reaching 17,9 m/s side and backwall canopies shall be removed	

Canopy

Top, side and back

Standard side and back wall 100% closed - scrims available on request.

Color outside grey, inside black – other colors on request

Canopy complies to B1 fire retardant standards (ISO 9239-1)

Ballast

Total	Varies between 1800kg – 7400kg
Per tower	Varies between 450 – 1900kg

Amount of ballast depends on:

- Self-weight of the structure (position of the tower)
- Interconnected tower bases or free-standing towers
- The use of an integrated staging system
- Friction coefficient between spindles-padding-sub soil

Staging

Layher scaffolding stage or Easyframe B stage, available as an option.

Floor dimensions	variable
Floor height	max +/-1,4 m
Floor loading	500kg/m ² – 750kg/m ²

Soundwing

Available as an option

Grounding

Available as an option

Side/Backstage area

None

Lifting

None n.a.

DIMENSIONS

FRONT VIEW 8X6

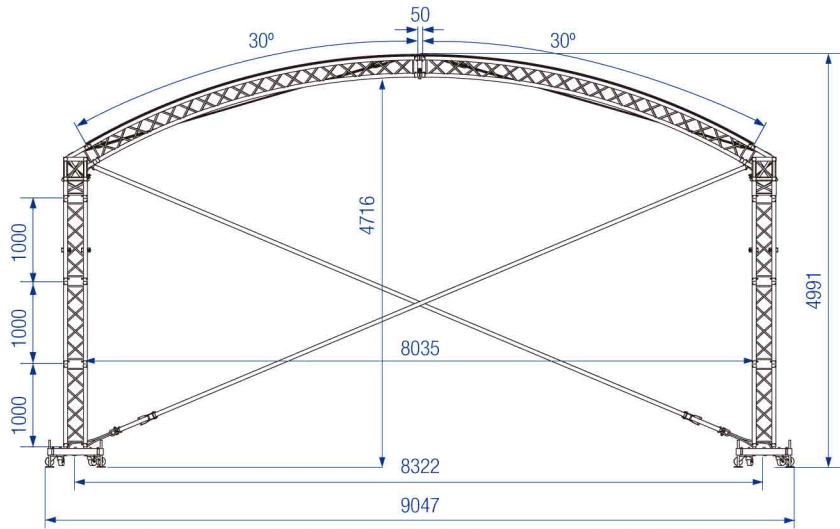

SIDE VIEW 8X6

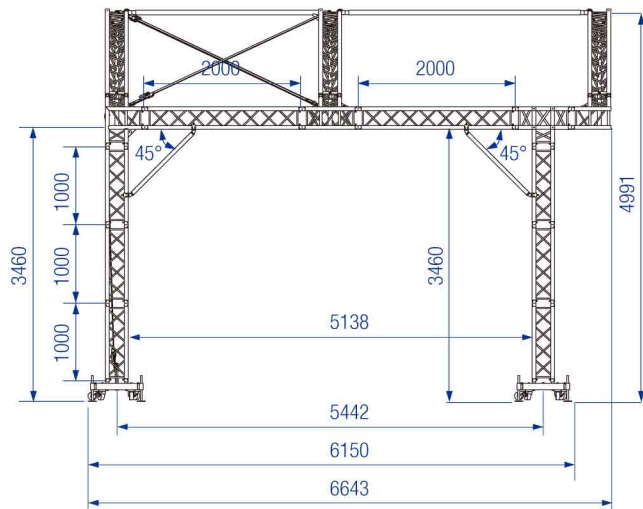

TOP VIEW 8X6

