

Photo: © Prolyte

PRODUCT FEATURES: PHC-500ST AND PHC-1000ST

- Available in 500 and 1000 kg load capacity versions.
- Standard lifting chain lengths: 10, 15, 20, 25m. (The hand chain is always two times the length of the load chain).
- Hand chain guide prevents toppling or jamming of the hand chain.
- High quality bearings to ensure smooth operation.

- Robust, black powder coated housing.
- Zinc plated and/or yellow chromated brake parts and guide rollers.
- Zinc plated load chain and hand chain.
- Rotating hooks on housing and chain.



PHC-500ST PHC-1000ST-1010

Manual Chain Hoists 500kg and 1000kg

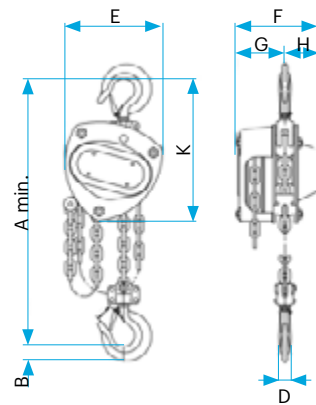

	A	B	D	E	F	G	H	K
PHC-500ST	350	21	16	145	140	80	60	240
PHC-1000ST	380	28	20	158	155	87	68	270

	load capacity	Chain size	lift per 1m hand chain overhaul	pull on hand chain at WLL	Weight
PHC-500ST-1010	500kg	5x15mm	26mm	210N	20kg
PHC-500ST-1515	500kg	5x15mm	26mm	210N	27kg
PHC-500ST-2020	500kg	5x15mm	26mm	210N	35kg
PHC-500ST-2525	500kg	5x15mm	26mm	210N	43kg
PHC-1000ST-1010	1000kg	6x18mm	24mm	240N	27kg
PHC-1000ST-1515	1000kg	6x18mm	24mm	240N	37kg
PHC-1000ST-2020	1000kg	6x18mm	24mm	240N	47kg
PHC-1000ST-2525	1000kg	6x18mm	24mm	240N	57kg

CHAIN BAG

The manual chain hoist can be equipped with standard chain bags fitting the chain or oversized chain bags that can also be used to transport the manual hoist.

QUALITY IN 2 VERSIONS

The manual chain hoists are available in a standard version and in a version with a rotatable hand chain guide. Both versions offer a 1000kg and a 500kg SWL capacity. These premium quality, basic hoists offer different chain lengths on both versions, optional black powder coating and a high quality zinc plated chain.

OPERATES FROM ANY POSITION

Using the rotatable hand chain guide the operator can work from any position, being able to follow and operate from any work position. This allows the operator to stand and work outside the danger zone near the load. The rotatable hand chain guide makes this hoist type specifically suited for tower and roof system applications, where the hoist is used in an inverted position.

PRODUCT FEATURES: PHC-500RHG AND PHC-1000RHG SERIES

- Available in 500 and 1000 kg load capacity versions.
- 360 degree rotating hand chain guide.
- High quality and easy serviceable brake system.
- Zinc plated and/or yellow chromated brake parts and guide rollers.
- Zinc plated load chain and hand chain.
- Chain guide and gearbox almost completely closed for maximum protection.
- Rotating hooks on house and chain.
- Available chain length: The RHG series hand chain hoist can be supplied with any preferred amount of load and hand chain. Used in combination with most of the MPT towers the hoist will be configured with 15m load chain and 3m hand chain (PHC-500RHG-0315).



PHC-500RHG-0315 PHC-1000RHG-0315
Manual Chain Hoists 500kg and 1000kg rotating hand chain guide

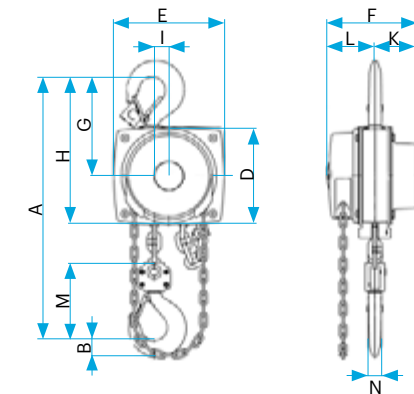

	A	B	D	E	F	G	H	I	K	L	M	N
PHC-500RHG	300	17	133	148	148	139	206	24	61	87	110	14
PHC-1000RHG	335	22	156	175	167	164	242	24	70	97	125	19

	load capacity	Chain size	lift per 1m hand chain overhaul	pull on hand chain at WLL	Weight
PHC-500RHG-0315	500kg	5x15mm	33mm	210N	15kg
PHC-1000RHG-0315	1000kg	6x18mm	20mm	300N	25kg