



Photo: Rigging Services, UK. Project Galleries Lafayette

StageDex is based on a special extruded aluminium profile. The top board is glued to the frame to reduce noise and vibration. All decks are available in metric and imperial sizes.

**TOP LINE SERIE**

- Internal reinforcement of corner
- Standard spigot entry on the topside of the deck to attach EasyRail system
- Birch plywood, water resistant quality
- Glued in 15mm wooden plate
- Non-slid hexagon layer
- loading capacity 750kg/m<sup>2</sup>

**BASIC LINE SERIE**

- Top option; Birch plywood, unfinished, indoor use only.
- Top option; Birch plywood, clear varnish, indoor use only.
- Top option; Birch plywood, black coating, indoor use only.
- No reinforced corner solution
- Glued in 15mm wooden plate
- loading capacity 750kg/m<sup>2</sup>



**SM-D-T**  
Birch plywood non slid top layer, non permanent outdoor use



Topline frame, reinforcement corner



**SM-DL-U**  
Birch plywood, unfinished, indoor use only



**SM-DL-C**  
Birch plywood, clear varnish, indoor use only

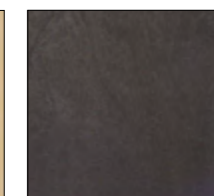

**SM-DL-B**  
Birch plywood, black coating, indoor use only



Photo: Extreme, Jordan

**SPECIAL TOP OPTION**

- Luxurious transparent decks for special applications. The transparent top board is made from durable, scratch-resistant Acrylic.
- Load capacity 500 kg/m<sup>2</sup>
- Can be combined with regular StageDex.
- Clear / acrylic top plate
- Frosted / acrylic top plate
- Maximum allowable temperature 70°C



SM-DL-D Clear  
SM-DL-DF Frosted

**CLEVER PARTS THAT MAKE THE DIFFERENCE**

1. Choose a top line frame to have the advantages of a top-based spigot entry, which allows simple and efficient mounting of handrails.

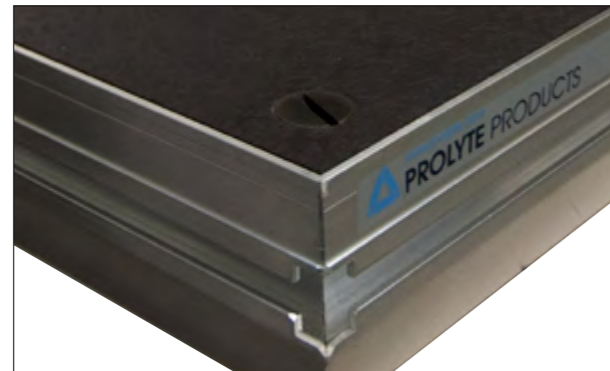

2. The universal leg fitting can hold square as well as round types of legs and fixates with one simple handle. The multifunctional profile offers several add-ons.



LEG TYPES	UNIFORMLY DISTRIBUTED LOAD kg/m <sup>2</sup>				
	80 cm	100 cm	120 cm	160 cm	180 cm
STAGE HEIGHT IN CM					
StageDex: (EN AW 6082 T6)	750	500	500	350	n.a.
LiteDeck: Tube 48 x 4 (EN AW 6082 T6)	750	750	500	500	350
Profile 40 x 40 x 3 (EN AW 6082 T6)	750	500	500	500	350
Tube 48 x 3 (S235JR)	750	750	500	500	500
Telescopic leg	450 < 800 mm	800 < 1200 mm	1200 < 1400 mm		
	750 kg	500 kg	350 kg		

☐ = Prolyte standard tube

n.a. = not allowed  
all data based on a standard deck of 2 x 1m

Calculated with 1/10 of the vertical load transferred into a horizontal load (conform DIN 15921 / EN 13814)

Loading types (for all decks except Acrylic)

Uniformly distributed load	750 kg/m <sup>2</sup>
Pointload F1	350 kg
Pointload F2	210 kg
Pointload F3	500 kg

The pointload should be applied to a minimum area of 50 x 50 mm. Pointload to be placed as indicated on drawing. 1 pointload total allowed.

Technical Specifications	
Types	standard, standard arched, basic
Frame	Aluminium (EN AW 6063 T6)
Top board	Plywood
Legs	48 x 3 mm (EN AW 6082 T6)
Legs with adjustable feet	48 x 3 mm (EN AW 6082 T6), with steel spindle on pvc base
Telescopic leg	48 x 4 / 60 x 5 mm (EN AW 6082 T6)
Maximum load	750 kg/m <sup>2</sup> UDL
Self weight	35,6 kg

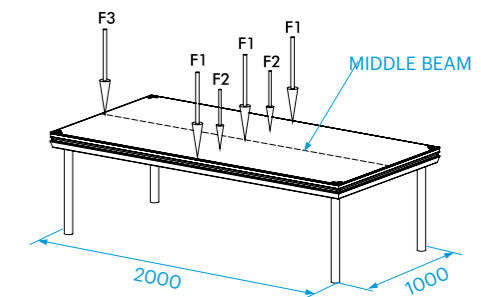

**DO**

- Check to ensure the stage floor is properly aligned and completely level.
- Check the application conditions of your stage, as the type of use is directly related to safety issues like handrails.
- Brace your staging legs when needed for stability.
- Make sure all stage elements are interconnected.
- Take notice of local regulations for stages and allowed purposes.
- Store StageDex upside down to decrease setup time.
- Maintain your StageDex at regular intervals.
- Inform your crew beforehand on safety procedures (like evacuation procedures) in case of emergency situations.
- Make sure your construction is properly grounded.

**DO NOT**

- Use materials in poor condition, the payload might be reduced substantially.
- Apply loads before knowing their exact weight and size.
- Exceed the maximum allowable load.
- Use unfinished StageDex top board in outside conditions.
- Exceed the maximum building height of the stage or its support frame.
- Use the hang-on profile without reducing the maximum allowable payload.
- Build your stage on unstable ground.
- Use StageDex elements as ballast for your roof without using the proper support frame.

**NEED TO KNOW MORE?**

Please go to [www.prolite.com](http://www.prolite.com) for more technical information on StageDex systems, manuals and loading tables. In the Prolyte BlackBook (technical background information) we provide more in-depth technical knowledge on stages and stage floors.

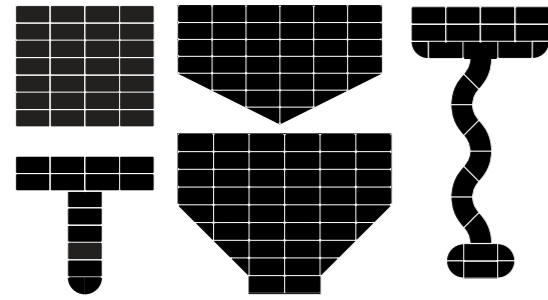

USE YOUR IMAGINATION

What if the systems flexibility would not limit your imagination in designing and building staging constructions? StageDex offers endless flexibility to create the designs you require, a variety of standard sizes and shapes as well as easy and often tool less mounting makes construction an easy task.

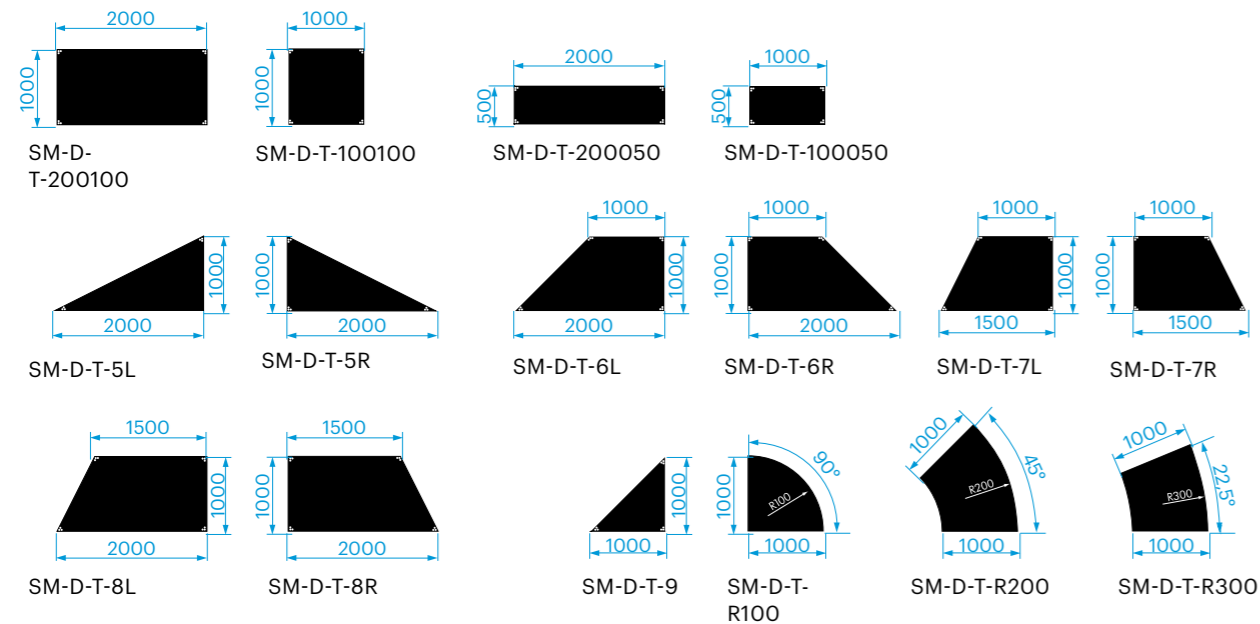

CIRCULAR STAGES

The Prolyte Group is able to fabricate circular stages that are actually based on curved segments. Each section or segment is handbuilt by our craftsmen, therefore small differences in size and shape may occur.



STANDARDS

Standards that apply to stages and temporary constructions:

DIN EN 1990 / Eurocode 0	Basis of structural design
DIN EN 1991 / Eurocode 1	Actions on structures
DIN EN 1993 / Eurocode 3	Design of steel structures
DIN EN 1995 / Eurocode 5	Design of timber structures
DIN EN 1999 / Eurocode 9	Design of aluminium structures
DIN EN 13814	Fairground and amusement park machinery and structures - safety
DIN 15921	Entertainment technology - Aluminium platforms and frames - Safety requirements and testing



The StageDex leg attachment system provides a straightforward yet ingenious engineering solution that assures fast, safe stage constructions.

- No tools needed
- The legs are fitted to the deck frame and are fixed in position by one simple handle
- Round as well as square legs can be mounted in the leg attachment system

Notice: The types of legs, and the length of the legs that are used, will determine the amount of loading that is allowed. Be sure to always check the loading table before you apply any loads to the decks.

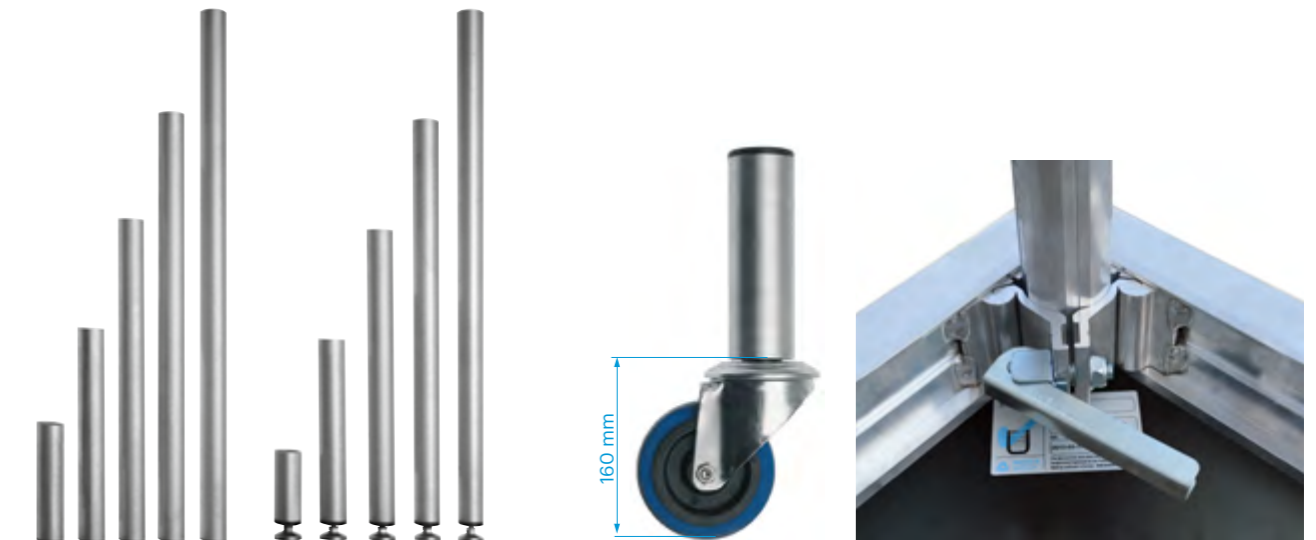

STANDARD LEGS

Round aluminium tube 48 x 3 mm in heights of 200-1000 mm. Code: SM-L-••A

ADJUSTABLE LEGS

Round aluminium tube 48 x 3 mm in heights of 200-1000 mm, with adjustable feet. Maximum angle of 5°. Code: SM-L-••A-ADJ

LEGS WITH FITTED CASTORS

Round aluminium tube 48 x 3 mm in heights of 300-1000 mm, with castor or castor with brake. Maximum of 160kg per leg with castor. Code: SM-L-••CAS-01 = single leg with castor  
SM-L-••CAS-02 = single leg with castor/brake  
SM-L-••CAS-03 = double leg with castor  
SM-L-••CAS-04 = double leg with castor/brake

TELESCOPIC LEGS

StageDex unique telescopic leg combines adjustable height and high loading capacity.

- Sturdy road-rugged mechanism
- Build-in tape measure for easy mounting

HOW DOES IT WORK?

- Release the two M10 hexagon socket head screws or crank handles.
- Extend the leg to its required length
- Lock the leg at both positions to guarantee optimal grip of the telescopic mechanism
- Measurements on the inside of the profile indicate the total length of the leg and safe operating areas
- Rubber leg caps prevent damage to your flooring system

TELESCOPIC LEGS - Standard available Lengths and Codes

CODE	Description
SM-L-45/60-ADJ	Telescopic leg 600-900 mm
SM-L-60/90-ADJ	Telescopic leg 600-900 mm
SM-L-90/140-ADJ	Telescopic leg 900-1400 mm
SM-L-ACC-01	Crank M10x25 for telescopic leg.

This can be used instead of the screws.





**STAGEDEX RAMP**

Designed to further expand the possibilities of the StageDex range, the multipurpose StageDex Ramp offers a perfect solution for rolling equipment on and off stage, wheelchair access, or more creative applications such as car shows, walkways and fashion catwalks.

The StageDex Ramp comprises three basic elements:

- Standard StageDex staging
- Adjustable legs fitted with stabilizers (SM-RP-L-ADJ-...)
- Aluminium side profiles (SM-RP-BE2)

The specially designed side profiles have been

engineered to absorb the forces from heavy loads, such as cars, meaning the StageDex Ramp can withstand up to 750 kg/m – the same allowable loading as standard StageDex staging.

The Ramp has a standard sloping angle of 7,5 degrees, but is adjustable between 0 and 22 degrees using a plate connected to the legs. This system ensures the resulting forces from loading are transferred at the correct angle into the leg. Notches on top of the profiles keep the staging in place once the ramp is built. A standard coupling profile allows the sloping section to be connected to staging at either end.

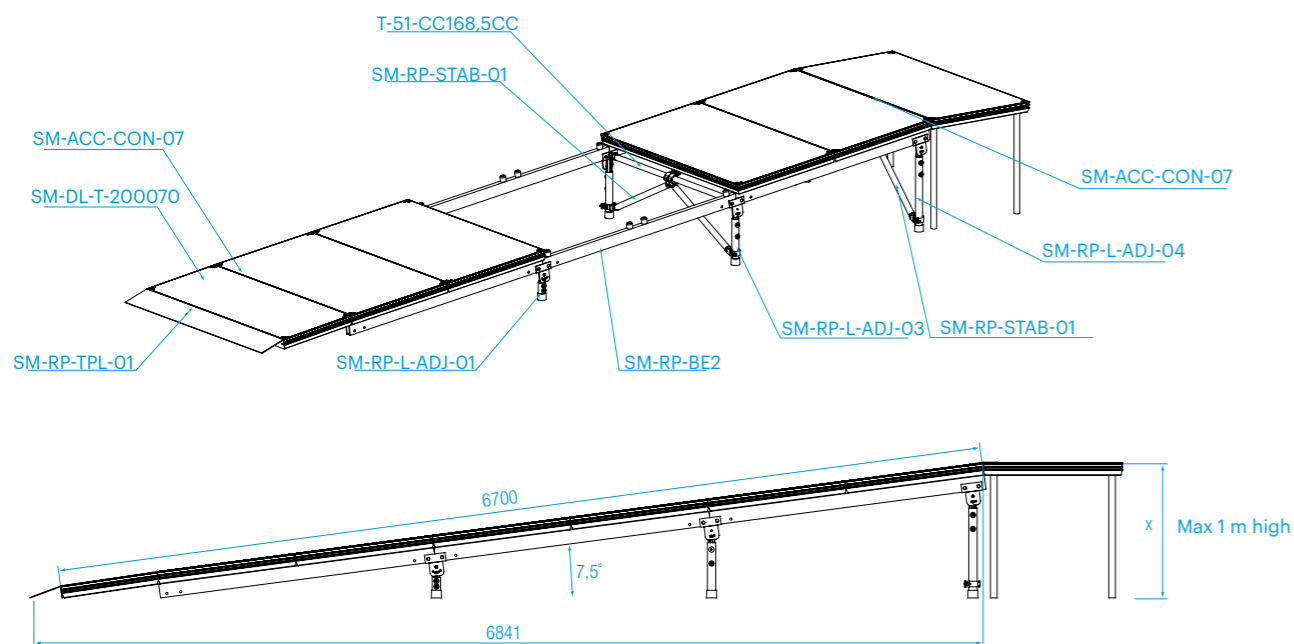

Photos: Prolyte

**EASYFRAME B**

**System Description:**

EasyFrame B is a support frame suitable for indoor or outdoor use. The frame racks are available in several heights and lengths. The frames connect to the legs with a standard 4-way connection by means of a locking pin. Due to the closed topside, assembly is possible with only one technician. After positioning, the frames are stable and freestanding, and will not topple over. Spindle feet, placed in the bottom of the frames, make it possible to level the stage at an exact position and to vary the height of your stage floor.

**Code:**

- SM-F-B-R• 000100, rack 1000 mm height, minimum stage floor height variable between 1200-1600 mm.
- SM-F-B-R• 000150, rack 1500 mm height, minimum stage floor height variable between 1700-2100 mm.
- SM-F-B-R• 000200, rack 2000 mm height, minimum stage floor height variable between 2200-2600 mm.

**Advantages:**

- Can absorb horizontal forces resulting from eventual wind forces on the roof.
- Interfaces for smaller Prolyte roof systems available.
- Fit for various brands of staging by using special adapters to secure your decks.
- The maximum allowable load of 750 kg/m<sup>2</sup> and 10% horizontal load are guaranteed.
- Standard stage elements provide your stage floor.
- Fast assembly, no tools and a minimum amount of loose parts.

**Ballast system:**

Stages are often used in combination with temporary roof structures. If used correctly, the weight of your stage floor may lower the ballast values of your roof construction. The EasyFrame B support system is constructed such that the complete stage floor is interconnected. If the stage is lifted at one end, the complete stage will be lifted. Only constructions that comply with these criteria may act as ballast system for roof constructions. Apart from this fact, the EasyFrame B is suitable to absorb the horizontal forces resulting from the base sections of the roof towers. Prolyte can supply interfaces for the smaller Prolyte roof systems.



**STEP 1**  
Place the leg with 4-way joint (SM-F-B-L....) where wanted. The leg is available in lengths of 1000 mm, 1500 mm and 2000 mm.

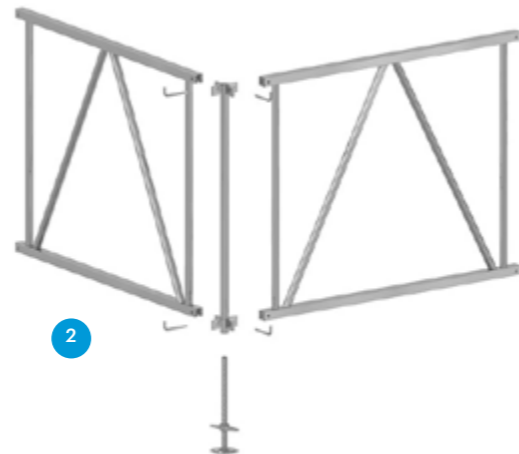

**STEP 2**  
Connect the frame rack (SM-F-B-R....) to the leg and fix with the L-pin (SM-F-A-LP16). The ladder frames connect to the 4-way joint by means of a pen/fork connection which is closed on the top side (the fork "rests" on the pen). After positioning, the parts can stand free, without toppling over. This makes the assembly of the locking pin easy.

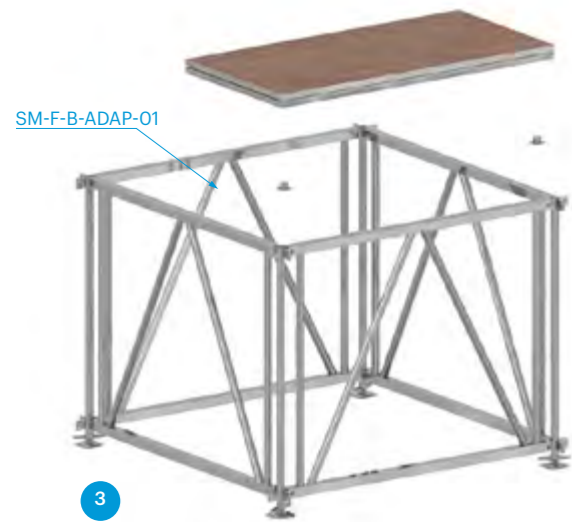

**STEP 3**  
Place the deck-to-frame adapter (SM-F-B-ADAP-01) in the leg fittings of your deck. Place the decks on top of the assembled frames. Level the stage by means of the spindle feet in the legs.



**DECK-TO-FRAME ADAPTER**  
In order to safely mount the decks to the EasyFrame B system, Prolyte has developed the deck-to-frame adapter. This adapter is mounted in the leg connection and prevents any horizontal movement of the decks.

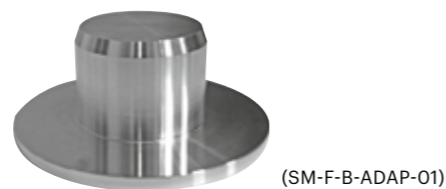

Photo: Scenos Techninis Servisas, Black Sea Arena, Georgia.

**EASYFRAME C**

**System Description:**

Based on customer experience, Prolyte created a multipurpose support frame that provides the ultimate in configuration flexibility. EasyFrame C is equally adaptable to use for stages, seating areas or tribunes.

**A strategic investment:**

The StageDex EasyFrame C can be used for flat stages as well as raised platforms or bleachers (tribunes). This makes the initial investment very economical, since only one system needs to be purchased for several applications. Ease of assembly also reduces build-up times. Free corridors, which can be created under the stage, allow for handy storage space for your empties and also serve as the ideal location for dimmer city or other uses.

**Easy does it:**

The setup of an EasyFrame C is fast, straightforward and requires only one tool. Due to the use of lightweight material, only one technician is needed to handle each part. There are two basic types of EasyFrame C: sub frame 1 varies in height between 100-150 cm, while sub frame 2 varies between 160-270 cm. All intermediate steps are either standard or tailor-made by means of the hole distance in the inside legs. Optional screw jacks provide levelling, or optional castors give you the opportunity to build a RollingStage as well. Standard StageDex are fitted to the top of the EasyFrame C system with a StageDex adapter, which fixes the decks horizontally as well as vertically.

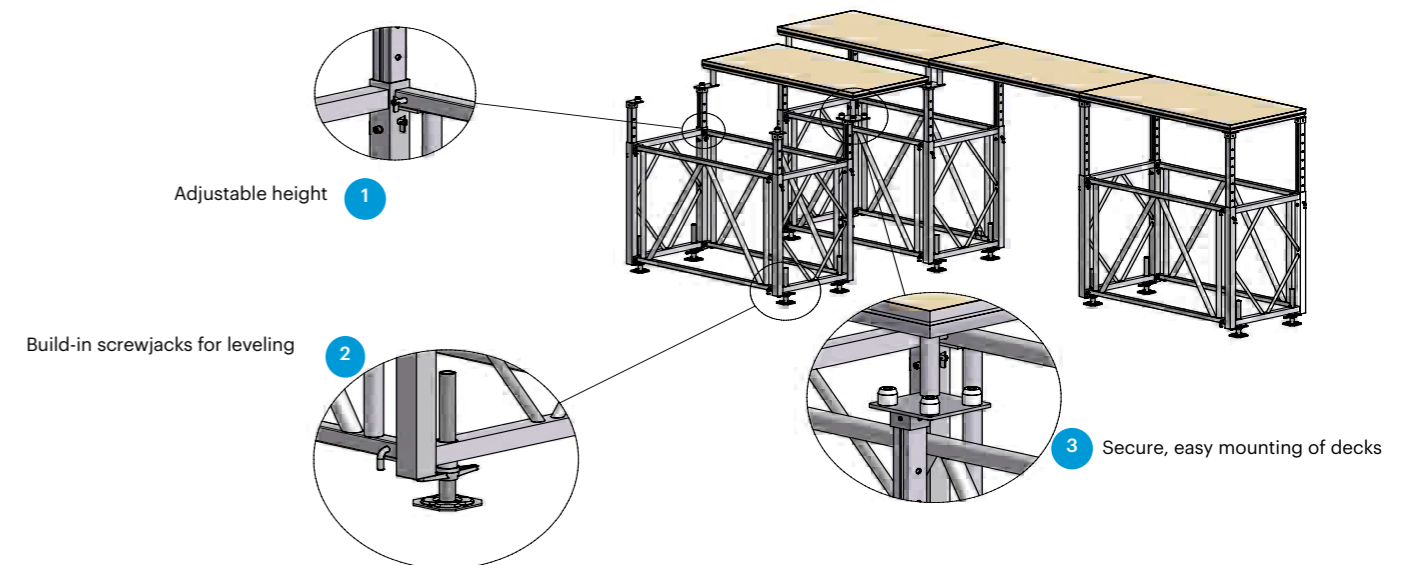



**STEP 1**  
Place the base frame (SM-TRB-F-...) at your desired starting point. Frames are available in heights: 1000 – 1500mm (number 01) or 1600 – 2700mm (number 02).

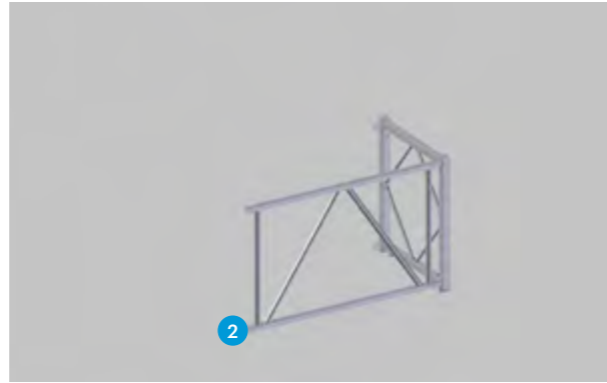

**STEP 2**  
Connect the side frame (SM-TRB-F-B-...) to the base frame with the L-pins (SM-F-A-LP16). After positioning the parts can stand free, without toppling over. This facilitates easy assembly of the locking pin.



**STEP 3**  
Connect the second base frame to the assembly, using the L-pins.

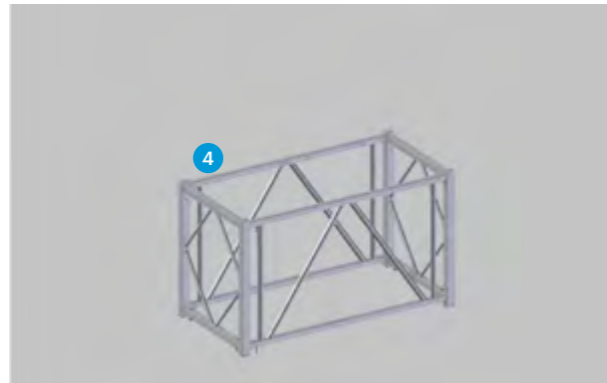

**STEP 4**  
Connect the final side to the assembly, using the L-pins.

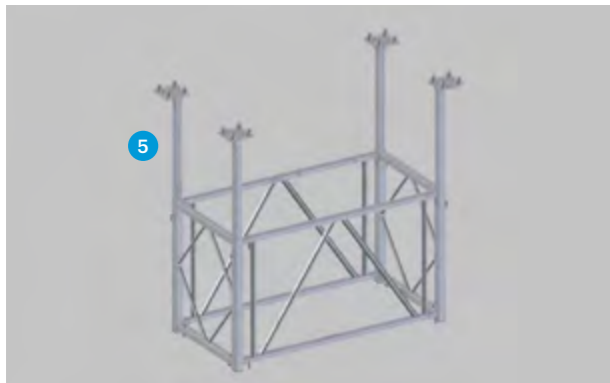

**STEP 5**  
Insert the extendable legs (SM-TRB-ADJ-LEG-...) in the base frames. Adjust them for the correct height and then secure them with the L-pin.



**STEP 6**  
Place your decks on top of the deck adapters (SM-TRB-D-ADAP-...).



Photo: Prolyte Sales, Space Roof training Starlight

**SYSTEM DESCRIPTION**

Probeam offers an economical and innovative system that combines the benefits of both scaffolding and StageDex staging systems. The Probeam main beam has wedge head couplers on both ends that connect simply by sliding the wedge head over the rosette and inserting the wedge into the hole. The Probeam cross beam has extended support ridges to fit the Probeam main beam. The exceptional strength and high stability of the Probeam guarantees symmetrical and foolproof construction.

**SYSTEM DETAILS**

- Probeam main beam available in lengths of 1000 mm, 2000 mm and 1036 mm and 2072 mm.
- Probeam cross beam available in lengths of 1000 mm, 2000 mm and 1036 mm and 2072 mm.
- The main and cross beams can be ordered without wood, with basic line wood black or with a top line wooden inlay.
- Covers can be ordered in 3-way and 4-way version, with or without centre hole.

**SIMPLE, FLEXIBLE, CONVERTIBLE**

The Probeam is designed for two different applications:

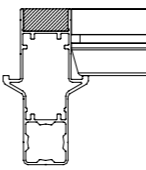
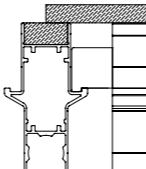
-  1 The Probeam converts the scaffolding system measurements (2072 mm) into the metric StageDex system, to create a floor on scaffolding size. The Probeam is fitted with a wooden inlay to overcome the 72 mm difference.
-  2 The Probeam system combined with a wooden inlay can be used as supporting frame when normal plywood is used as flooring system.

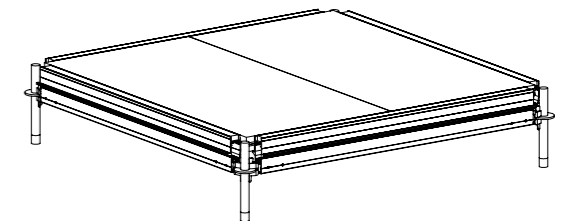

Standard Probeam 2072 x 2072





**PRODUCT DESCRIPTION:**

Being one of the major suppliers of temporary roof and staging systems, Prolyte products are often used in combination with Scaffolding systems. To facilitate the work of our users when building a stage, Prolyte has developed a system to integrate roof system towers and base sections in a Layher stage floor. By integrating and interconnecting these two systems you can create a safe and secure stage system.

**ADVANTAGES:**

- Significant ballast reduction; the self weight of the stage can be subtracted (when the stage is sufficiently braced)
- Lateral forces through guy-wiring or wind on the tower sections are absorbed by the substructure
- Clean and even building area for the roof system

- Towers are all built on the same height
  - No need to invest in standard base sections
  - 100% flexible in x/y direction
- Prolyte has created a fully flexible and x/y axis adjustable base system, to take into account that the number of combinations between tower position, stage floor height and position compared to the side of the stage floor are endless.

The size and strength of the components derives from a maximum load structural analysis for the standard LT and ST roof systems. The beams are fitted with a special non-friction based sliding system to allow horizontal forces as well as vertical forces. The frames are utilised to hold cross beams to accommodate additional ballast. All steel frames are delivered with black powder coating.

MORE INFORMATION ON REQUEST



Photo: Metro Productions LTD New Zealand. Project: King Kong premiere in Wellington.

**EASYRAIL**

**System Description:**

Handrails and other accessories from the EasyRail range can easily be attached to the decks by inserting a spigot in a pre-bolted hole on each corner of the deck. This makes it possible to assemble the rails after the decks are built, as they are fully independent of the sides or the

underlying constructions of the stage. For the basic line decks, StageDex has developed special adapters for the spigots, which slide into the side profiles of the decks. The EasyRail comes in two different versions, both in compliance with the applicable standards (DIN 15921).



EasyRail mounted on top line deck.

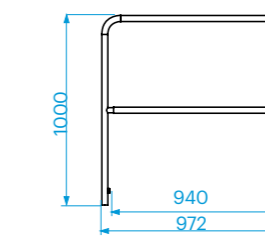

EasyRail railing. SM-RAIL-L100.

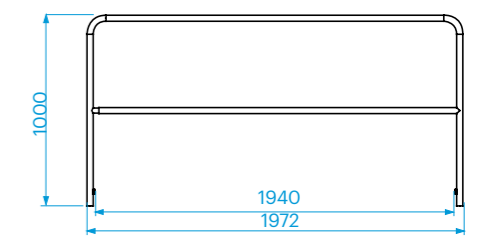

EasyRail railing. SM-RAIL-L200.



EasyRail mounted on basic line deck.

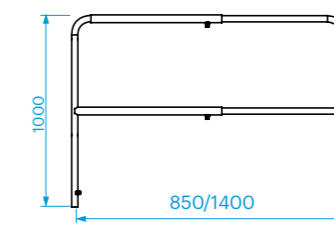

EasyRail railing. SM-RAIL-L85/140.

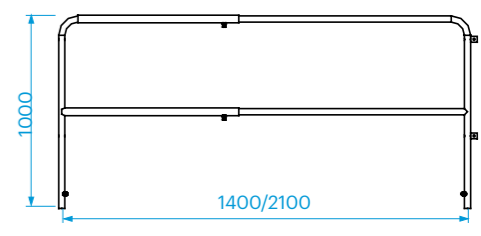

EasyRail railing. SM-RAIL-L140/210.

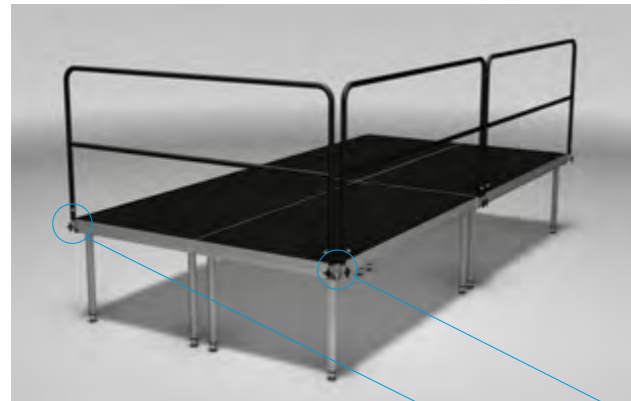

**EASYRAIL 30 KG/M**  
The light-duty version of the EasyRail can resist a horizontal loading of 30 to 60 kg/m. This railing type can be used for stages or areas with no public access. This is the case for most commonly used stages. For top line decks, the railing can be easily mounted on top of the decks by simply bolting a 26 mm spigot to the pre-drilled hole. The railing is available in a fixed and an adjustable type.

**FIXED RAIL**  
SM-RAIL-L100, length 1000 mm.  
SM-RAIL-L200, length 2000 mm.

**ADJUSTABLE RAIL**  
SM-RAIL-L85/140, adjustable from 850 to 1400 mm.  
SM-RAIL-L140/210, adjustable from 1400 to 2100 mm.

**EASYRAIL 30 KG/M - BASIC LINE DECK**

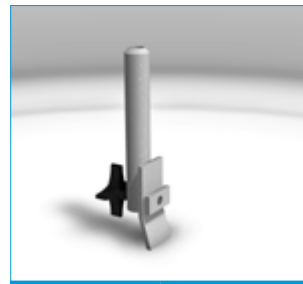

Description: Spigot for handrailing  
Code: SM-RAIL-ATT-04

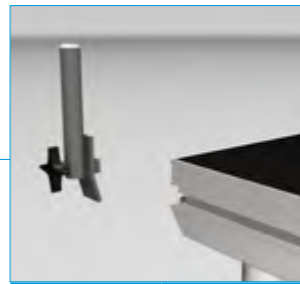

Description: Spigot for handrailing  
Code: SM-RAIL-ATT-04



Description: Spigot for handrailing  
Code: SM-RAIL-ATT-04

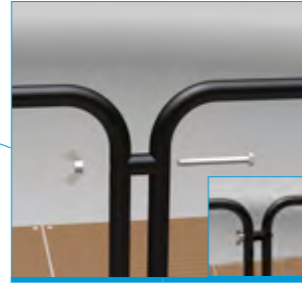
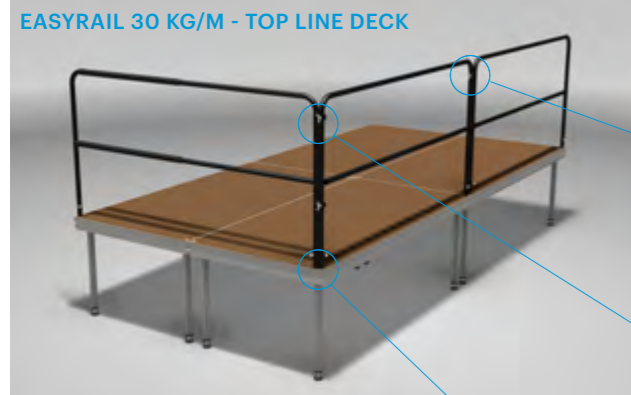

Description: Railing connector  
Code: SM-RAIL-CON



Description: Spigot for handrailing  
Code: SM-RAIL-ATT-01

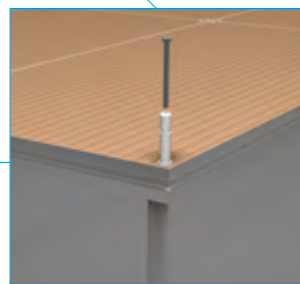

Description: Spigot for handrailing  
Code: SM-RAIL-ATT-01  
Bolt M12x150  
Code: BM-M12x150

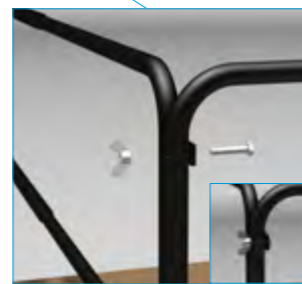

Description: Bolt M10x55  
Code: BM-M10x55  
M-10 Wingnut  
Code: BM-M10WNUIT  
M-10 Spring-wash  
Code: BM-M10-SW

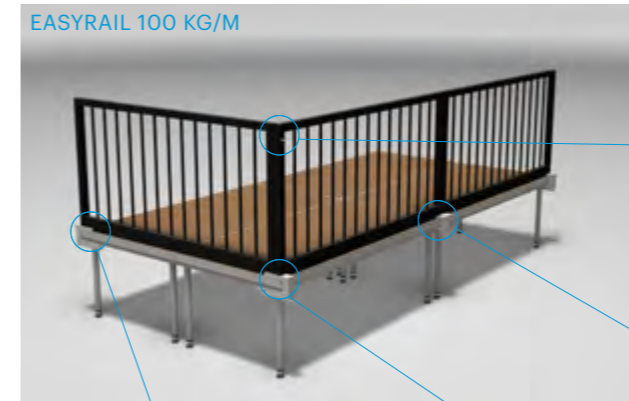

Description: Spigot attachment  
Code: SM-RAIL-ATT-08  
SM-RAIL-ATT-08-01  
For Easy-Frame B  
Code: SM-RAIL-ATT-03  
For Easy-Frame C  
Code: SM-RAIL-ATT-06

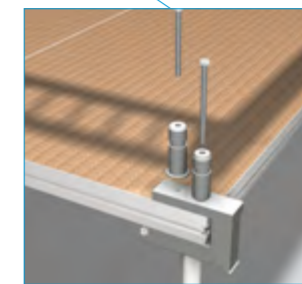

Description: Spigot for handrailing  
Code: SM-RAIL-ATT-02  
1x Bolt  
Code: BM-M12x140  
1x Bolt  
Code: BM-M12x180

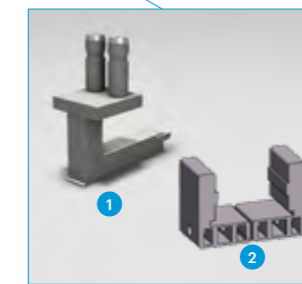

Description: Spigot attachment  
Code: SM-RAIL-ATT-09  
SM-ACC-CLP-06  
For Easy-Frame B  
Code: SM-RAIL-ATT-05  
For Easy-Frame C  
Code: SM-RAIL-ATT-07

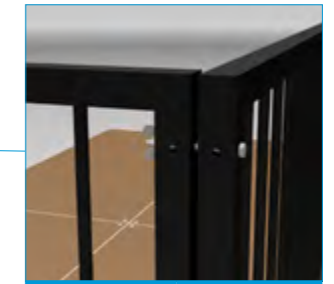

Description: Bolts  
Code: BOLT M10X130  
Nuts  
Code: M10 WINGNUT + WASHER



Description: 2x Bolt  
Code: BM-M12x180

**EASYRAIL 100 KG/M**  
The heavy-duty version of EasyRail can resist a horizontal loading of 100 to 200 kg/m. This railing type can be used in all circumstances, including portions of the staging with public access, as the railing is in compliance with the applicable regulations. The railing can be easily mounted on top of the decks by simply bolting a 40 mm spigot to the pre-drilled hole, and then using the special railing adapter. The railing adaptor has an extra M12 hole drilled in front of the spigot hole. An extra spigot can be bolted in place here to provide a connection for a corner rail. This type of rail can only be used in combination with top line decks.

**RAILING LENGTHS**

SM-RAIL-H-L100 RAILING 100KG L=100CM  
SM-RAIL-H-L200 RAILING 100KG L=200CM

SM-RAIL-H110-L100 RAILING 100KG H=110CM, L=100CM  
SM-RAIL-H110-L200 RAILING 100KG H=110CM, L=200CM

**CORNER PIECES**

SM-RAIL-H-L093C RAIL FOR CORNER 100KG L=93CM  
SM-RAIL-H-L193C RAIL FOR CORNER 100KG L=193CM

SM-RAIL-H110-L093C RAIL FOR CORNER 100KG,H=110CM, L=93CM  
SM-RAIL-H110-L193C RAIL FOR CORNER 100KG,H=110CM, L=193CM

**ACCESSORIES**

SM-RAIL-ATT-02 Spigot 40 mm for top line deck  
SM-RAIL-ATT-03 Adaptor for 100 kg/m rail for top line deck





Photo: Musical Oorlogswinter, The Netherlands



Photo: Belcult Project, Belarus. Project: Palace of the Republic, ST roof with EasyFrame B

**ADJUSTABLE STAIR**

**System Description:**

This unique, fully adjustable, staircase consists of separate units which can be combined to form a staircase between 1 m minimum and 3,2 m maximum height. The units are based on four main beams of 60 x 6 mm tube to which the stair steps are connected. The stair steps are flexible and have a varying angle of 45 to 60 degrees. The adjustable stair is designed for a maximum loading of 500 kg/m<sup>2</sup>.

**BASIC ELEMENTS**

**Top side:**

SM-STAIR-500, basic element with 6 steps. The upper step aligns with the stage floor. This basic element is connected to the stage by means of a profile that is bolted to the stage with a T-head bolt (M10 x 40 mm) which is placed in the StageDex profile.

**Bottom side:**

The SM-STAIR-510 base section. Connects to the stair elements by means of a CCS7 coupler combined with the CCS7 hinge (CCS7-H-FM-90).

**STEP UNITS**

To elongate the basic element, extra step units can be mounted. Units range from 1 to 5 steps. Several units can be coupled to reach the maximum allowed height. The extra units are connected using the standard CCS7 coupling system.

- SM-STAIR-501, 1 STEP BEAM.
- SM-STAIR-502, 2 STEP BEAM.
- SM-STAIR-503, 3 STEP BEAM.
- SM-STAIR-504, 4 STEP BEAM.
- SM-STAIR-505, 5 STEP BEAM.

**HANDRAILS**

Mounting the handrails completes the staircase. The railing can be combined by utilizing three parts:

- SM-STAIR-520 is the adjustable basic part, can be coupled, to cover the full height of your stair.
- SM-STAIR-521 is the rounded end part.
- SM-STAIR-522 is the rectangular end part to which another railing can be coupled.

The railing parts can be mounted only on the SM-STAIR-500 and the SM-STAIR-505. The railing is mounted to the main tube using the standard spigot (SM-RAIL-ATT-01), which is bolted to the tube using a M12 x 200 mm bolt.

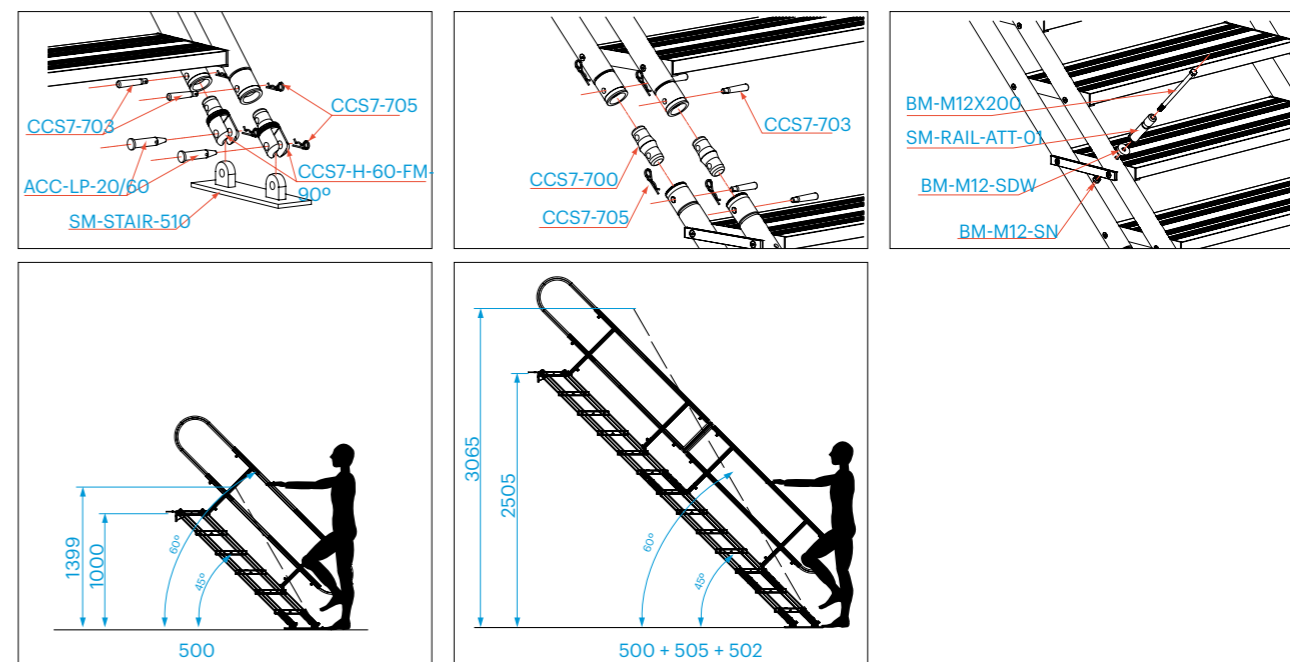

STAIR HEIGHTS USING DIFFERENT COMBINATIONS

All measurements in mm	500	500 + 501	500 + 502	500 + 503	500 + 504	500 + 505
A (stair angle 45 degree)	1000	1344	1537	1731	1924	2118
B (stair angle 60 degree)	1399	1636	1873	2110	2346	2584
All measurements in mm	500 + 505 + 501	500 + 505 + 502	500 + 505 + 503	500 + 505 + 504	500 + 505 + 505	
A (stair angle 45 degree)	2311	2505	2699	2891	3075	
B (stair angle 60 degree)	2829	3065	N/A	N/A	N/A	

maximum allowable stair height 3,2 m.



Photos: Metro Productions LTD, New Zealand Project: King Kong Premiere, Wellington, New Zealand

**MODULAR STAIR**

**System Description:**

Separate stair units can be combined to create a stair of any desired height in steps of 20 cm by simply bolting stairs together. The units can be connected at both sides, which makes it possible to create a staircase of different widths as well as several heights. The railing can be connected to the sides of the stairs, but also in between the steps, thereby creating the possibility to have a separate up and down staircase.

The measurements of the individual stair units are 910 x 225 mm. Each stair unit has an angular profile to one side, making it possible to fit the stairs directly to the decks to create an even level for the last stair. The stair unit can be mounted using the T-bolts. The SM-STAIR-CON-01 special clamp is available to mount stair units to the legs.

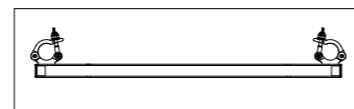
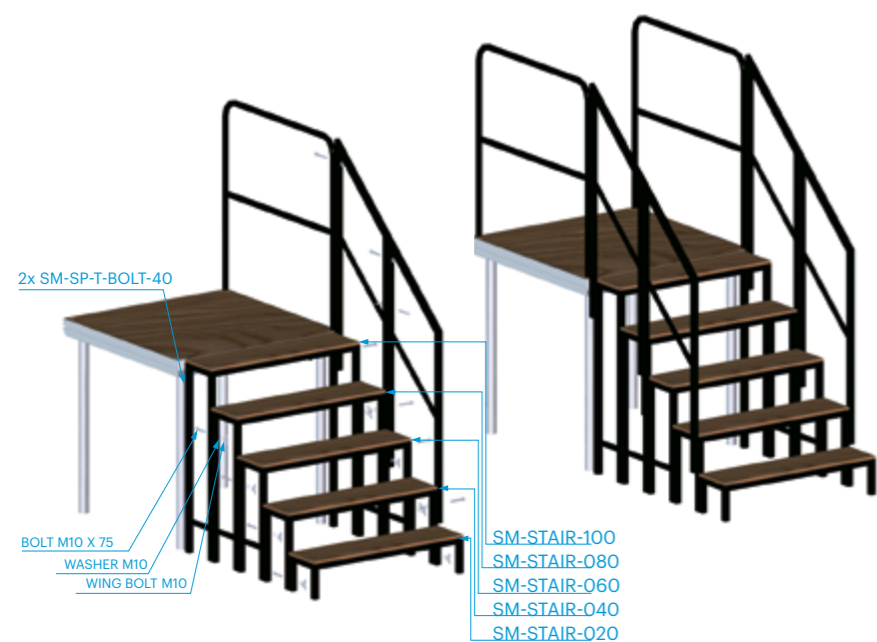

100cm SM-STAIR-CON-01  
200cm SM-STAIR-CON-02



Photo: Prolyte Group

**STAGEDEX DOLLY**

As an extension of its StageDex product range, Prolyte has added two dollies that are tailored to market requirements.

**BUILT TO LAST**

- The sturdy flatbed dolly has been developed to transport 20 decks, simply stacked on top of one another. This flatbed dolly is ideal for use in larger venues and for large-scale rental.
- Galvanised steel frame
- Design allows nesting for empty storage or transport
- Easy to manoeuvre due to extra-large wheels
- Fitted with 2 swivels and 2 fixed castors for easy steering
- Integrated handles

**PRODUCT SPECIFICATIONS: SM-ACC-DOLLY-01**

Dimensions	L2080 x W1020 x H1276 mm
Weight (empty):	92,8 kg
Weight (loaded):	773 kg
Capacity:	20 pcs StageDex 2x1

**SLIM FIT**

The more compact and manageable 6-deck dolly is designed for use in smaller venues, theatres and hotels. Due to the upright position of the decks, this dolly is small enough to fit through any door.

- Galvanised steel frame
- Design allows nesting or tipping for empty storage or transport
- Fitted with 2 swivels and 2 fixed castors for easy steering
- Narrow width – at 60cm it fits through doors and is based on standard truck dimensions
- Pre-fabricated slots to stack the decks on the dolly
- Integrated handles

**PRODUCT SPECIFICATIONS: SM-ACC-DOLLY-02**

Dimensions	L2075 x W600 x H1191 mm
Weight (empty):	60,4 kg
Weight (loaded):	265 kg
Capacity:	6 pcs StageDex 2x1

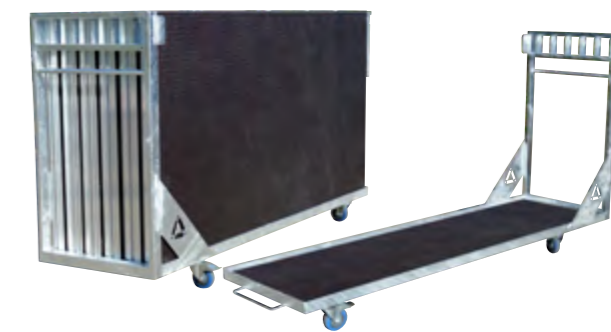

**STAGEDEX LEVELLER SM-ACC-CON-01**

Use the StageDex leveller to achieve precise levelling of your stage system and to prevent any vertical movement between the decks. Simply slide the cube into the side profile of the decks. Once the adjoining deck is placed,

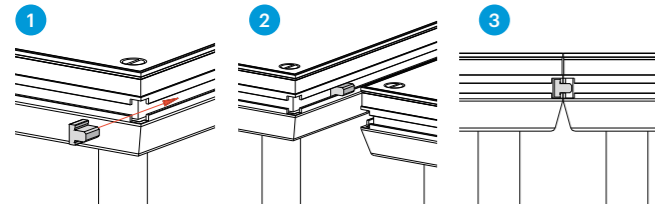

the StageDex leveller keeps both decks at precisely the same height. A safe and even stage floor, free from tripping hazards, is the result. The levellers can be delivered in several lengths on request.

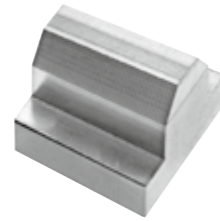

**STAGEDEX CONNECTOR SM-ACC-CON-02**

The StageDex Connector not only keeps your stage floor exactly level, but connects the decks as well. The deck connector slides into the side of the profile and is fixed with the aid of a simple hex key; it can be used in combination with the StageDex Leveller. The StageDex Connector is specially designed for circumstances where the

leg-to-leg clamp cannot be mounted, including:

- Low stages. There are no legs or the legs are too short to be able to mount the clamp.
- Angular or curved stages. The centre-to-centre distance of the legs at the angular corners of the stage is too large to mount the clamp.

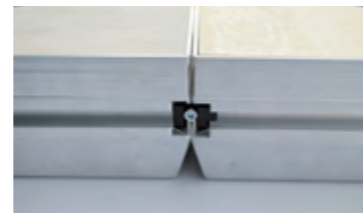
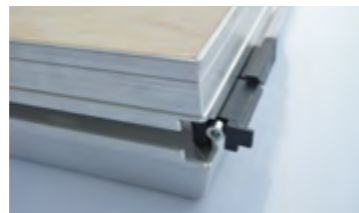
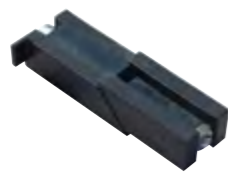

**COUPLING PROFILE**

The coupling profile provides an easy method of coupling your StageDex system while still allowing elements of the staging to be raked at a certain angle. This offers

the ideal solution for building ramps, sloping walkways or passageways for wheelchairs. The profile slides into the side of the decks; the adjoining deck is safely attached. The maximum raking angle is 30 degrees.

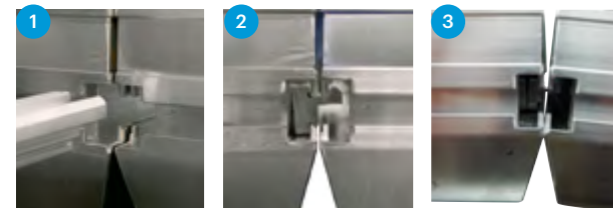

COUPLING PROFILE	
SM-ACC-CON-03	15 cm
SM-ACC-CON-04	35 cm
SM-ACC-CON-05	85 cm
SM-ACC-CON-06	135 cm
SM-ACC-CON-07	185 cm
SM-ACC-CON-08	600 cm

**STAGEDEX LEG BRACKET SM-ACC-CON-09**

Steel bracket for positioning the stage and keeping legs in place. For tiered seating or multi level stages.

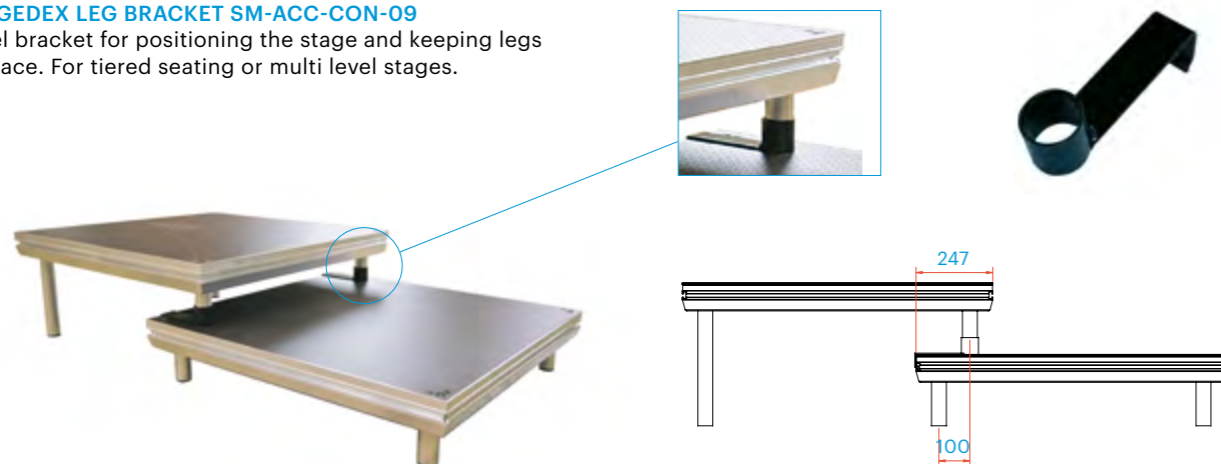

**LEG-TO-LEG CLAMP SM-ACC-CLP-01/02**

As well as the SM-ACC-CLP-01, the leg-to-leg clamp that connects two legs, Prolyte has designed the SM-ACC-CLP-02 that connects four legs. Both clamps are easily mounted; tools are not required. The clamps absorb the horizontal forces on the stage floor and guarantee a close fit of the decks.

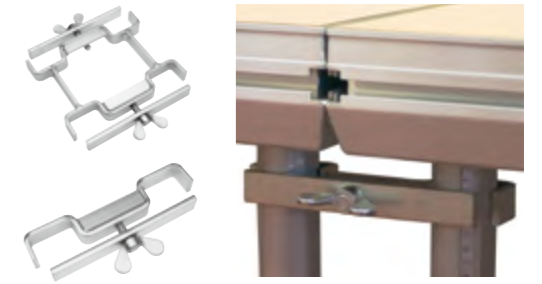

**DEX-TO-DEX CLAMP SM-ACC-CLP-03**

After your decks are mounted to the legs or support structure, they can be connected to each other using this clamp to ensure a sturdy connection between the decks. Using the clamp will prevent any unwanted vertical movement of your stage floor and will absorb the horizontal loading applied to the decks.



**CLICK-ON STAGEDEX PROFILES SM-CT-ATT**

One simple click and the profile is mounted to your deck! There are two click-on systems available: skirting profile (SM-CT-ATT-(06 t/m 09)) and toe board profile (SM-CT-ATT-(11 t/m 13)). Each profile works with a simple click and lock system and requires no tools to secure into place. These timesaving products can be locked on from the top for quick and easy assembly.



The skirting profile is developed to create an easy way to attach skirting to your decks, finishing the look of your platform or stage neatly. This profile is available in lengths of 470 mm, 970 mm and 1970 mm. A Velcro strip is delivered with this profile to facilitate the attachment of skirting. The skirting profile is developed to create an easy way to mount a toe board to your platform or staging area, creating a safe zone and preventing chairs from skidding off. This profile is available in lengths of 470 mm, 970 mm and 1970 mm.

**T-HEAD BOLT SM-SP-T-BOLT-40**

The T-head bolt can be placed in the side profile of the deck. It can be used to attach anything that requires bolting in place, from panels and signs to set pieces or special accessories. The bolts are available in several lengths.

